

PROFILING:

MARIAM SUHAIL



How to Light Yourself

How to Light Yourself

Mariam Suhail

2024

Pencil on paper

A4 size (2 drawings)

The document reads as pages from an instruction manual. It starts with a simple diagram explaining basic installation of the ubiquitous Ring Light, popular with most early content creators. There is however a second voice, questioning the viewer's reluctance to embracing their inevitable digital existence, a second life of immortal continuance.

The space that exists between the real world and the online one is a wide spectrum. The line shifts to different points of the spectrum for different people. For some it is categorical that the real, physical world be considered primary reality while the digital or virtual remains secondary, or something to be wary of; it is not real, it is 'pretend', it can be manipulated, it has to be kept at bay. For some it is one and the same thing. IRL or virtual, they are already singular beings, effortlessly morphing, shifting, presenting. There is also the in-between user, straddling both ends at will and convenience, enjoying the benefits of a blurred reality. This user is content with not always being aware, not always being in control, experiencing the chaos as being the organic nature of life itself.

HOW TO LIGHT YOURSELF FOR DIGITAL CONTENT.

SECTION 1,1: USING A RING LIGHT WITH TRIPOD & DEVICE MOUNT.

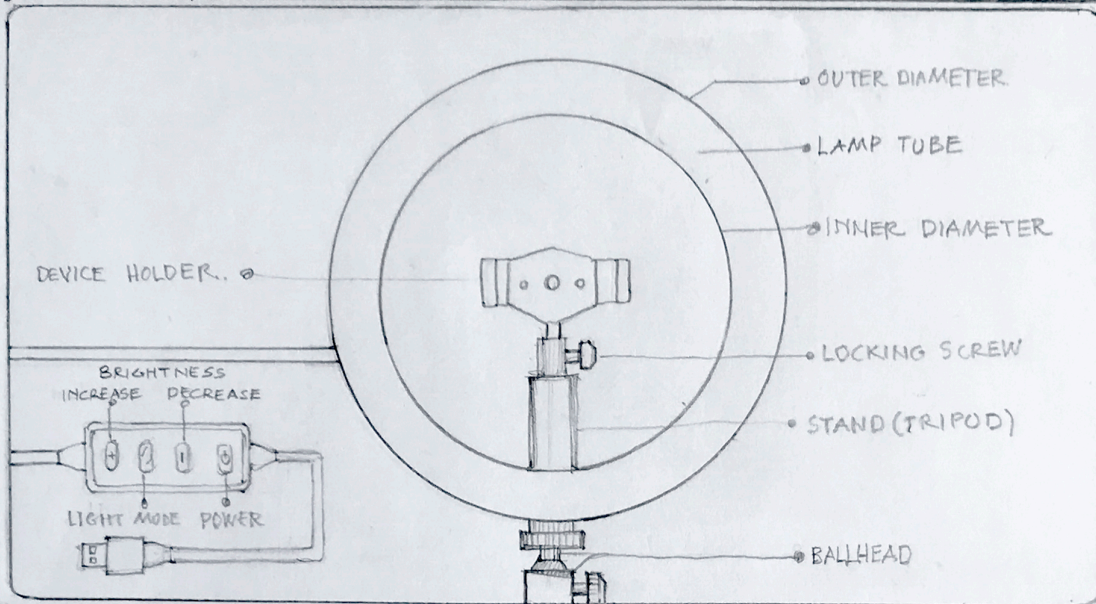

IT IS IMPERATIVE THAT YOU UNDERSTAND THAT WHAT YOU'RE RESISTING IS 'THE' NEW REALITY. YOU THINK IT'S YOU, RESISTING SOMETHING SMALL AND KEEPING IT AT BAY, YOU ARE IN FACT THE TINY CREATURE ABOUT TO BE FLATTENED INTO A WALL BY A GIGANTIC FORM.)

HOW TO LIGHT YOURSELF FOR DIGITAL CONTENTION

SECTION 1,2: SETTING UP YOUR DEVICE WITH THE RING LIGHT

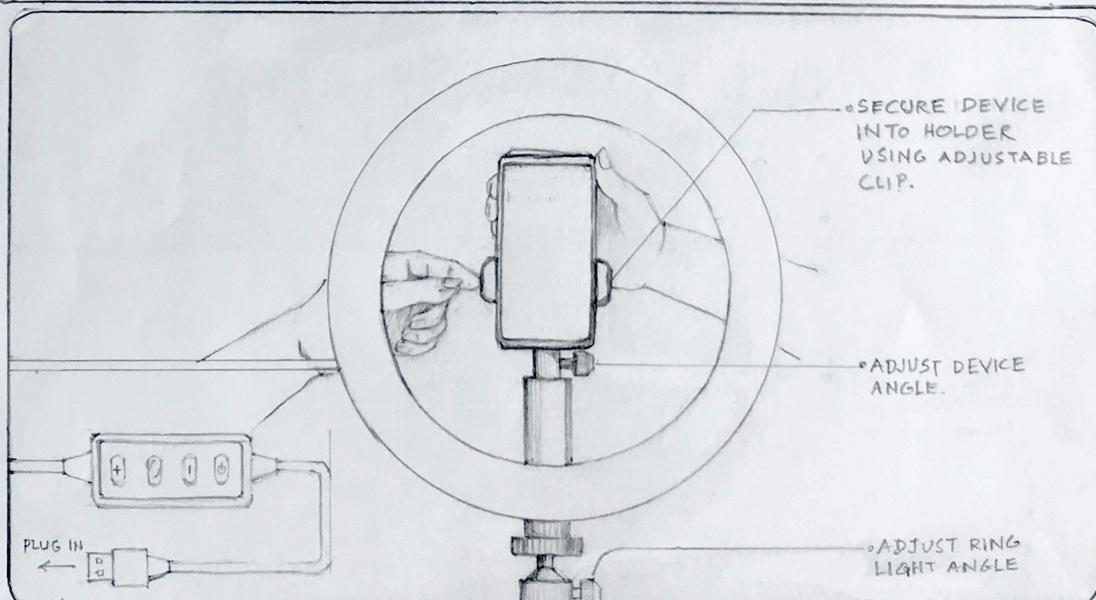

(IT IS PREPOSTEROUS THAT YOU THINK YOU ARE LIVING A NORMAL LIFE BY STAYING AWAY FROM A DIGITAL EXISTENCE. YOU ARE IN FACT SLOWLY CEASING TO EXIST.)

HOW TO LIGHT YOURSELF FOR DIGITAL CONTINUANCE

SECTION 1.3: ADJUSTING FOR OPTIMUM LIGHTING.

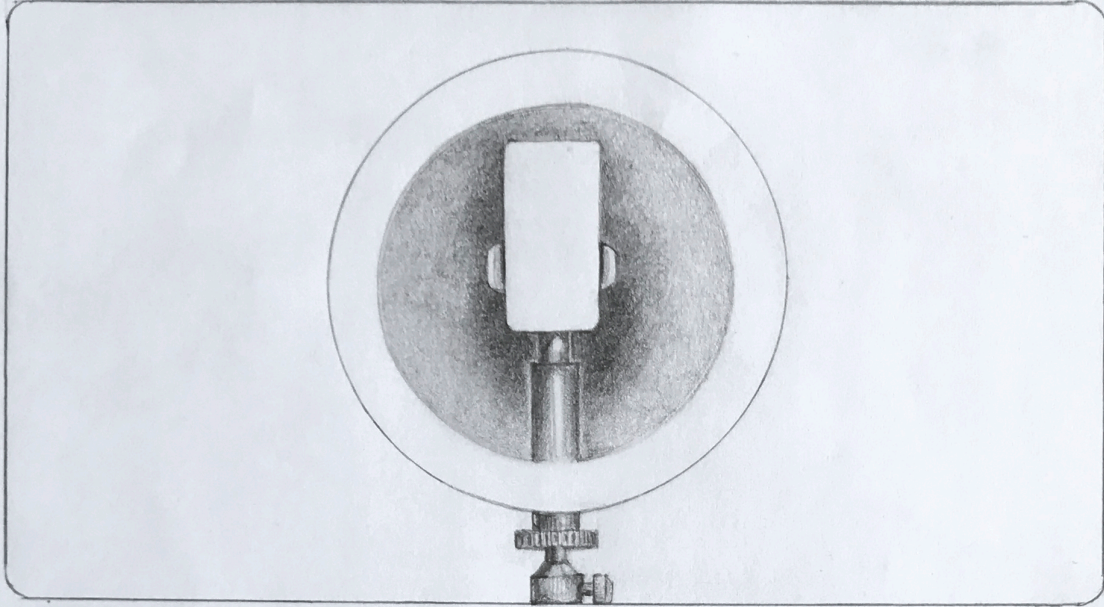

YOU HAVE TO SLOWLY BUT SURELY NURTURE YOUR DIGITAL SELF, FEED IT, WATER IT, LOVE IT, BUILD IT UP, MAINTAIN IT, DEVELOP IT, REDEVELOP IT, REINVENT IT AND CONTINUE THE PROCESS DAILY, RELIGIOUSLY, ENDLESSLY, JUST AS YOU TEND TO YOUR PHYSICAL BEING, PERHAPS EVEN MORE.

HOW TO LIGHT YOURSELF FOR DIGITAL CONTENTMENT

SECTION 1.4:

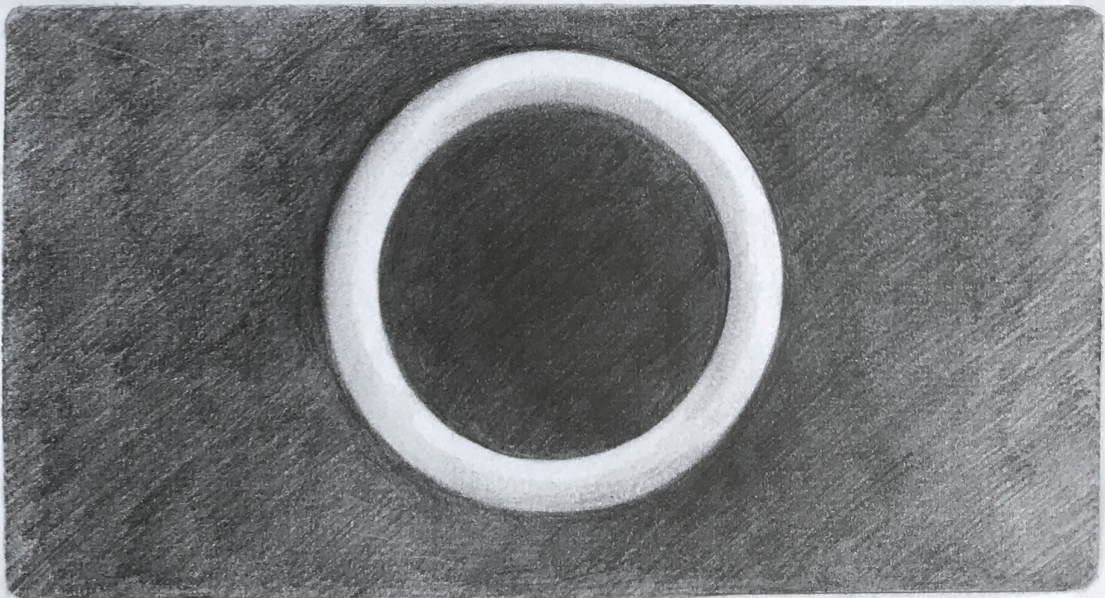

FIND YOUR LIGHT. ENTER THE VOID.